

Dec. 3, 1940.

J. B. GARRIGA

2,223,561

BEEHIVE

Filed Aug. 8, 1939

3 Sheets-Sheet 1

FIG. 1

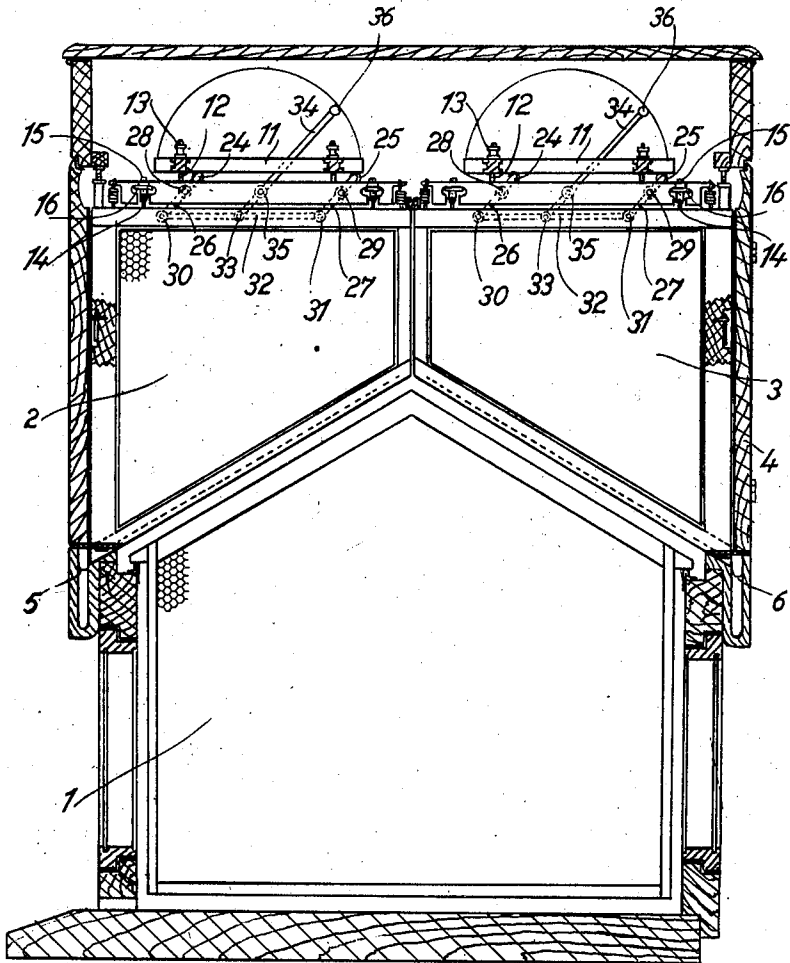

Inventor
J. B. Garriga:
by
W. S. Evans,
Attorney.

Dec. 3, 1940.

J. B. GARRIGA

2,223,561

BEEHIVE

Filed Aug. 8, 1939

3 Sheets-Sheet 2

FIG. 2

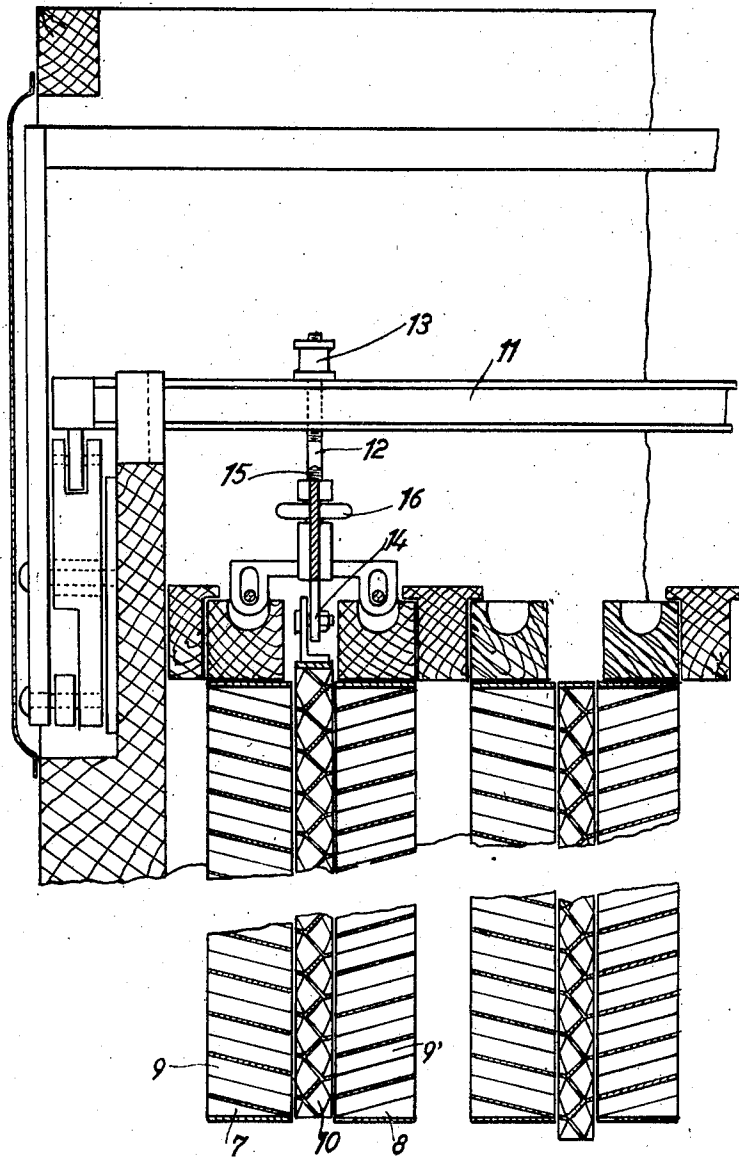

Inventor
J. B. Garriga:
by
W. S. Swann:
Attorney.

Dec. 3, 1940.

J. B. GARRIGA

2,223,561

BEEHIVE

Filed Aug. 8, 1939

3 Sheets-Sheet 3

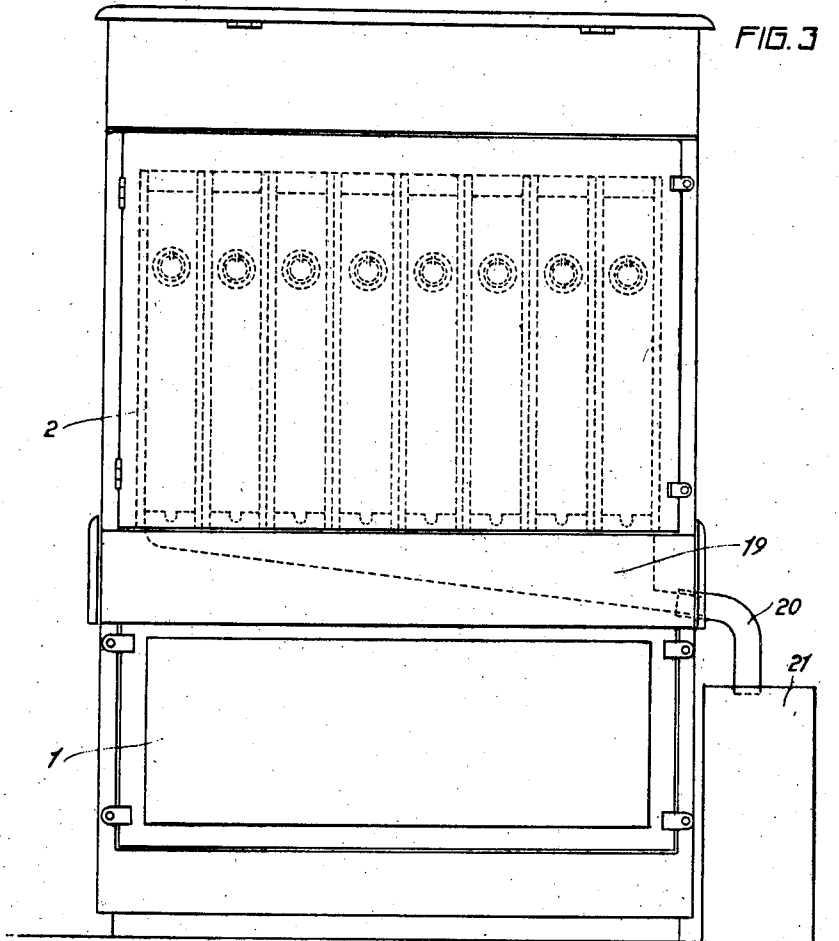

FIG. 3

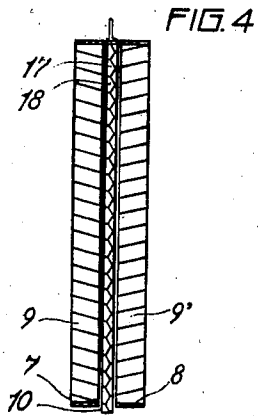

FIG. 4

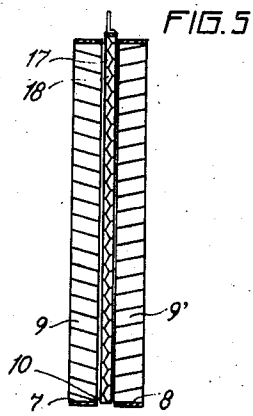

FIG. 5

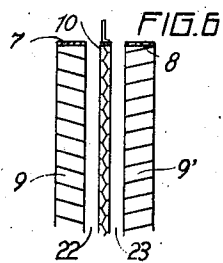

FIG. 6

Inventor
J. B. Garriga
by
W. E. Evans
Attorney.

UNITED STATES PATENT OFFICE

2,223,561

BEEHIVE

Juan Bizcarro Garriga, Igualada, Barcelona,
Spain

Application August 8, 1939, Serial No. 288,957
In Spain April 21, 1939

3 Claims. (Cl. 6—2)

Beehives with cells made of metal have been constructed now for some time; these are preferably made of aluminium since the qualities of this metal and of its alloys are very suitable for the purpose.

By the use of the beehive cells according to my invention all the operations of extracting the honey from the hives are greatly simplified by dispensing with manipulations in the interior of the hives with the result that the work of collecting the honey, which is long, fatiguing and even dangerous, is converted into a short and easy operation, which can be performed by any person.

On the other hand the bees are not annoyed by the operations which have to be carried out in order to gather and store the honey, thus avoiding diminution in the amount of honey produced, all of which is to the benefit of the bee-keeper.

It follows from the improvements herein referred to that the extraction of the honey can be carried out in the same hive without the bee-keeper having to resort to fumigation, nor need he come into contact with the bees thereby avoiding all danger of being stung.

The principal feature of the invention resides in the fact that the cells are composed of three parts, two of them being lateral parts and a third central part hereinafter referred to as the matrix wall. The matrix wall is adapted for a certain extent of movement relatively to the lateral or side parts whereby the matrix wall is enabled to take up a suitable position whereby the honey produced and contained in the cells can drain towards the outside and pass to receptacles which can be conveniently removed by the bee-keeper.

Other advantages and features of the invention will hereinafter be described.

As is well known, the cells constructed by the bees consist of a very large number of small receptacles, cells or vessels of hexagonal section joined together in juxtaposition so that they touch each other at the sides top and bottom. The bottoms are constituted by a pyramid of triangular section the sides of which are equal and are connected together at an equal inclination, so that the cell is constituted as a whole by a hollow body of hexagonal section with a pyramidal bottom, the arrangement being such that the bottom of each cell acts partly as the base of three other contiguous cells.

The bodies of the cells form two symmetrical series with openings leading to each side of the cell, each one of these series occupying part of

the thickness of the cell and a central wall or matrix wall forming the bottoms of the cells and separating the cells of series from those of the other. The central axis of each cell is at an opposite inclination to the cell on the other side, thus preventing the escape of the honey which remains stored and contained in the cells.

The invention is diagrammatically illustrated by way of example in the accompanying drawings in which:

Figure 1 is a front sectional elevation of a beehive constructed according to the invention.

Figure 2 is a detail in vertical transverse section on an enlarged scale, of part of two cells.

Figure 3 is a side elevation of the hive showing how the honey is extracted from the cells.

Figures 4 and 5 are theoretical diagrams on a reduced scale showing the relative positions of the side walls of the cells.

Figure 6 shows diagrammatically a modification.

The hive has provided at 1 the habitation of the bees, above which are provided two series of cells, as at 2 and 3, which are mounted in a wooden frame 4, which is itself mounted, as at 5 and 6, between the walls of the habitation 1 the said cells being capable of being removed from and replaced in this frame.

According to the present invention each cell consists essentially of three enclosing parts. Two of the said parts 7 and 8 (Figures 4 to 6) form the longitudinal prismatic cavities such as 9, 9', of hexagonal section, and the other part 10, which is adjustably mounted between the first two parts, forms the bottoms of the said cells in the form of triangular pyramids, the said bottoms being arranged in such a way that those on one side form the bottom of the cells on one side and the others form the bottom of the cells on the other side. The relative positions of these three parts are variable to suit requirements as will be explained hereinafter.

The three parts or members above referred to composing each cell are constructed with the greatest precision, so that by suitably connecting them together, the walls of the cells of the side parts may be extended and their bottoms fit exactly to the matrix or central wall so as to produce when assembled complete cells.

The matrix or dividing wall of each cell (Figures 1 and 2) is mounted on a supporting member 11 by means of a screw-threaded rod 12 which passes through the supporting member 11, and on which is screwed a nut 13 which rests on the supporting member so that the matrix or dividing

wall in each case may be adjusted in the vertical direction.

The central or matrix wall 10 which carries the bottoms of the cells corresponding to the side portions 7 and 9 is mounted by means of linkage 14 (Figure 2) on a screw-threaded pin 15, on to the screw thread of which is screwed a nut 16 by means of which it is possible to determine exactly the correct position of the matrix wall 10 with respect to the side walls 7 and 8, so that the longitudinal hollow parts of the cells shall coincide exactly with the corresponding bottoms.

All the matrix or central walls of the cells of a hive are mounted in a supporting member such as 11, so that they can be caused to slide simultaneously as a whole when so desired by the bee-keeper.

It is by means of this sliding movement that coincidence is obtained between the bottoms of the cells in each matrix wall and the longitudinal hexagonal cavities of the cells, so that the matrix wall assumes with respect to the walls on either side a position as shown in the cell illustrated on the right hand side of Figure 2, when the bee-keeper wishes to extract the honey from the cells.

This adjusting movement is shown diagrammatically in Figures 4 and 5. In Figure 4 is shown the position of the matrix wall 10 with respect to the side walls 7 and 8 when the cell is in position to receive the honey produced by the bees, the bottoms of the cells provided in the matrix wall being adjusted to the hexagonal openings of the cells formed in the two side walls. In Figure 5 the matrix wall has been moved longitudinally with respect to the side walls 7 and 8, with the result that at the positions 17 and 18 the ends of the hexagonal openings such as 9 are uncovered, so that the honey contained in the cells 9 escapes in a continuous stream from the top downwards. The result of this is that the honey automatically flows from the lower part of the cell and for the purpose of collecting it a collecting receptacle 19 (Figure 3) is placed in the hive which has connected to it a curved pipe 20 through which the honey flows from the receptacle 19 to an externally disposed receptacle 21 whence it is removed by the bee-keeper.

Each cell is of trapezoidal form as will be seen from Figure 1, so that the cells can conveniently be provided above the part 1 of the hive.

The invention is not limited to the particular construction hereinbefore described. Thus for example instead of arranging the matrix wall to be movable longitudinally in relation to the side walls, the discharge of the honey from the cells may be effected by imparting a lateral movement to the side walls so as to separate them from the matrix wall in a horizontal direction as indicated in Figure 6. In such case, owing to the hexagonal recesses being separated from their respective bottoms, channels such as 22, 23 are formed, down which the honey escapes to the lower part of the cell.

In the case shown in Figures 1, 2 and 3 it is of importance to the bee-keeper that the cells should be provided with means for raising the matrix walls as a whole. This can be effected by various

mechanisms, one of which is hereinafter described by way of example.

The matrix walls of the cells on each side of the hive are suspended from or connected to the rectangular section supporting members 11, carried on rollers 24, 25 mounted at the upper ends of links 26, 27 which are pivoted on spindles and the lower ends of which are articulated at 30, 31 to a horizontally extending bar 32, to which is also articulated at 33 a lever 34 the pivot pin of which is located at 35 and which is provided with a knob or handle 36. There is thus formed a system of articulated parallelograms controlled by the lever 34.

By turning the lever 34 by means of the handle 36 from right to left, the above mentioned system of articulated parallelograms causes the rollers to rise, thus elevating the rectangular supporting members 11 and consequently the matrix walls of the cells as a whole. By moving the lever 34 in the opposite direction the matrix walls are returned to their original positions after the honey has flowed from the cells.

This mechanism may be replaced by any other mechanism which will produce the same result.

In the foregoing description no mention has been made of the known practical operations which the bee-keeper will have to employ when using metallic beehive cells, such for example as the covering of the cells with a thin coating of wax so that the bees shall be in their habitual element; when this coating of wax is broken owing to the movement of the cells as hereinbefore described, the bees themselves will instinctively proceed to repair the damage.

The invention has been described with reference only to cells made wholly or partly of a metal such as aluminium or alloys of aluminium, but is applicable to cells made of other materials.

I claim:

1. A beehive including cells for the honey made of a number of fixed parts with movable parts interposed, the fixed parts being set at an inclination and forming the walls of the cells and linkage operated through an operating lever for raising said movable parts out of coincidence with the lower ends of the stationary parts to permit the honey to flow from the cells.

2. A beehive including cells for the honey made of a number of fixed parts and movable parts the fixed parts being set at an inclination and forming the walls of the cells and the movable parts being disposed between the fixed parts and forming the bottoms of the cells and means for moving the bottoms of the cells in a vertical direction out of coincidence with the ends of the fixed parts to permit honey to flow from the cells.

3. A beehive including cells for the honey made of a number of fixed parts and movable parts, the movable parts being set at an inclination and forming the walls of the cells and the fixed parts being disposed between the movable parts and forming the bottoms of the cells and means for moving the movable parts in a direction away from the fixed parts so as to enable the honey to flow from the bottoms of the cells.

JUAN BIZCARRO GARRIGA.